



Riera Nadeu 

CONTINUOUS SCREEN_Centrifuges®

FOUNDED IN
1952





Innovation from
Barcelona

More than
2000 projects Worldwide

Quality equipment
Since 1952

Taylor made
projects

Low maintenance
machines

Energy efficient
solutions



500F

Since 1980



Innovations

- _Simplicity.
- _Compact design.

Benefits

- _Continuous process for high filtering solid cakes.
- _Low maintenance.
- _Reliability at competitive price.
- _Compact design.
- _High “g” factor.

Clients



500F

Operating principle



- 1 _ Feeding pipe
- 2 _ Collector/s
- 3 _ Basket
- 4 _ Filter mesh or screen
- 5 _ Solids discharge endless screw
- 6 _ Gear box
- 7 _ Driving belts
- 8 _ Torque limiter
- 9 _ Frame
- 10 _ Main monitor

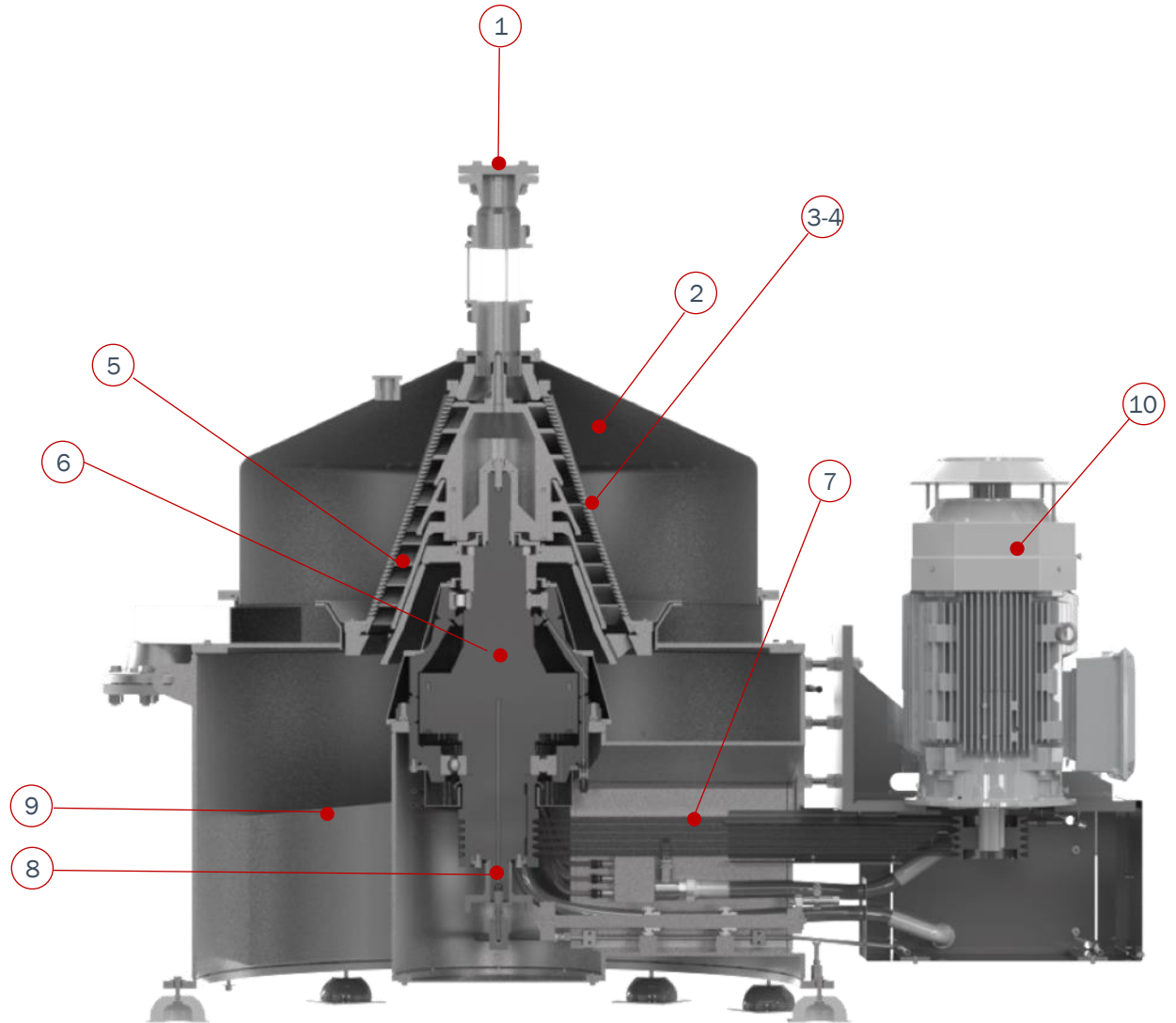

500F

Operating principle

LIQUID COLLECTORS
FILETR MESH
FILTERING BASKET
SOLIDS DISCHARGE ENDLESS SCREW



- 1 _ Feeding pipe
- 2 _ Collector/s
- 3 _ Basket
- 4 _ Filter mesh or screen
- 5 _ Solids discharge endless screw
- 6 _ Gear box
- 7 _ Driving belts
- 8 _ Torque limiter
- 9 _ Frame
- 10 _ Inspection gate
- 11 _ Main monitor
- 12 _ Lubrication unit

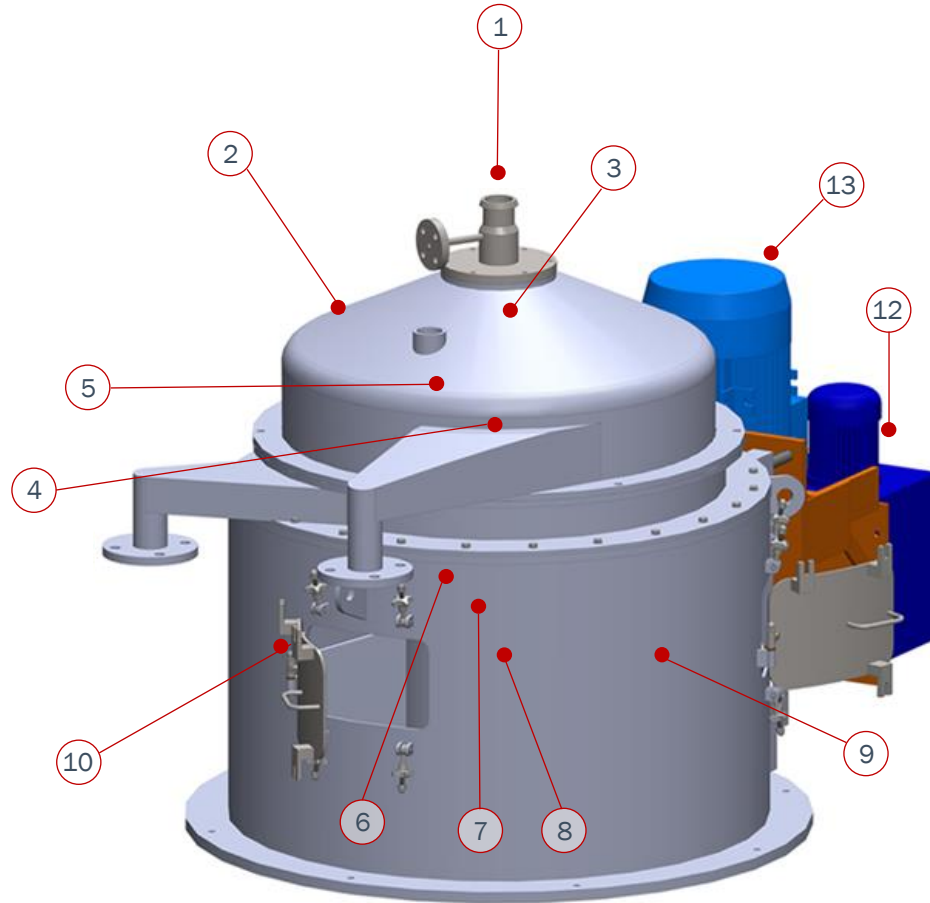

500F

Operating principle



- Continuous suspension feeding on the top.
- Washing and mother liquor collection on the upper part of the machine.
- Continuously bottom wet solid discharge.

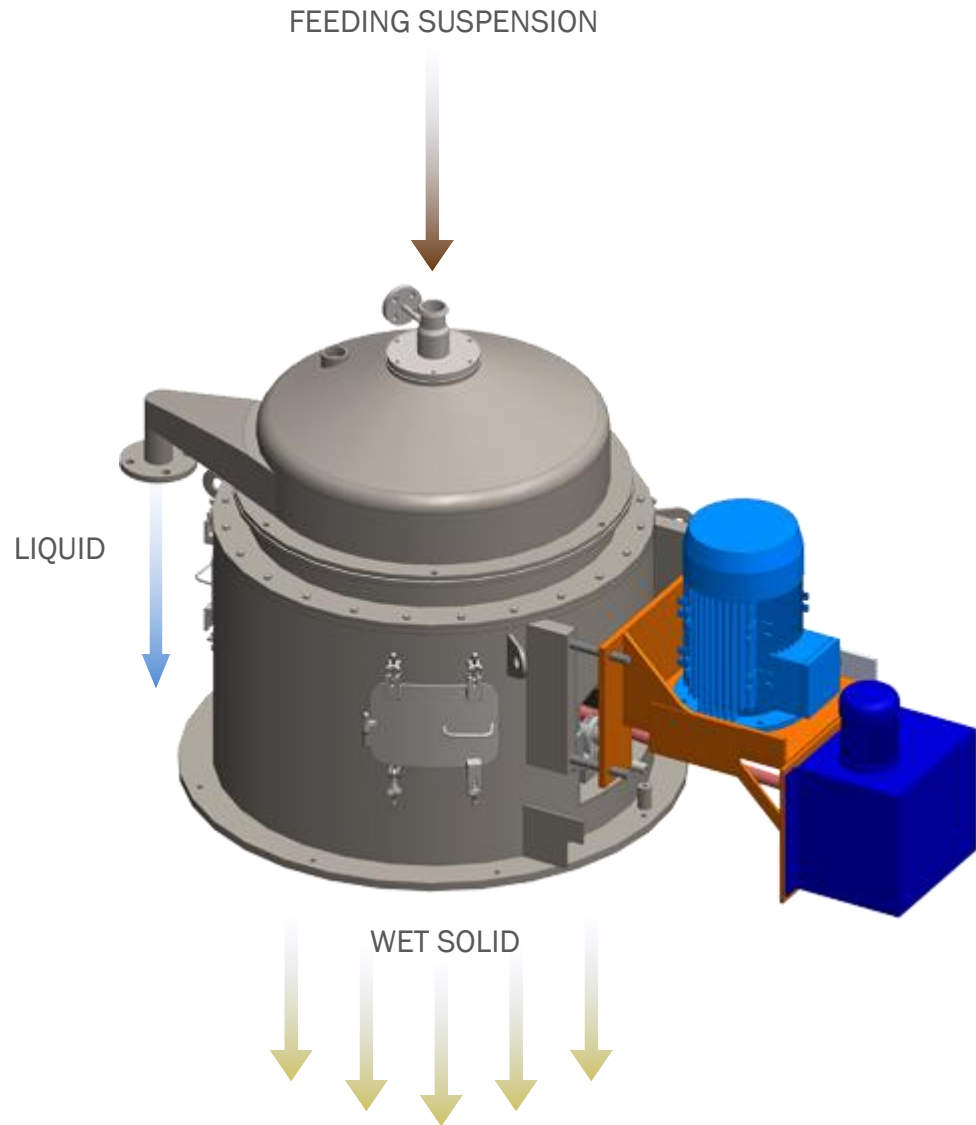

500F

Operating principle



FEEDING SUSPENSION

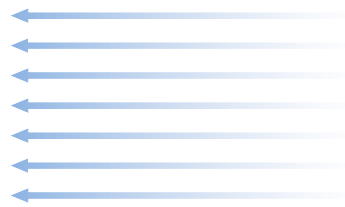

WASHING

MOTHER LIQUOR

- 1 _ Feeding suspensión.
- 2 _ Washing.
- 3 _ Mother liquor.
- 4 _ Wet solid.

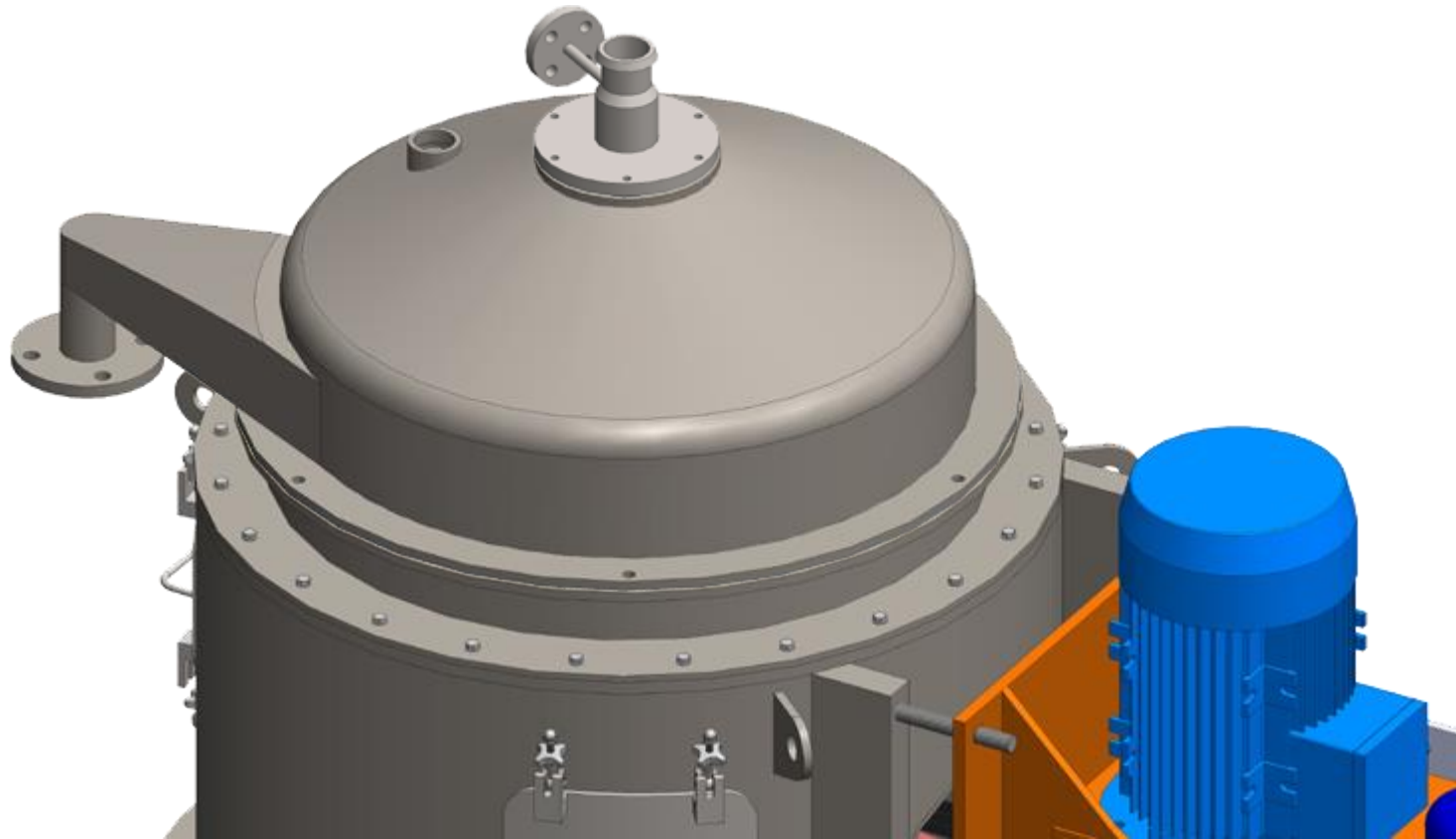

500F

Installation



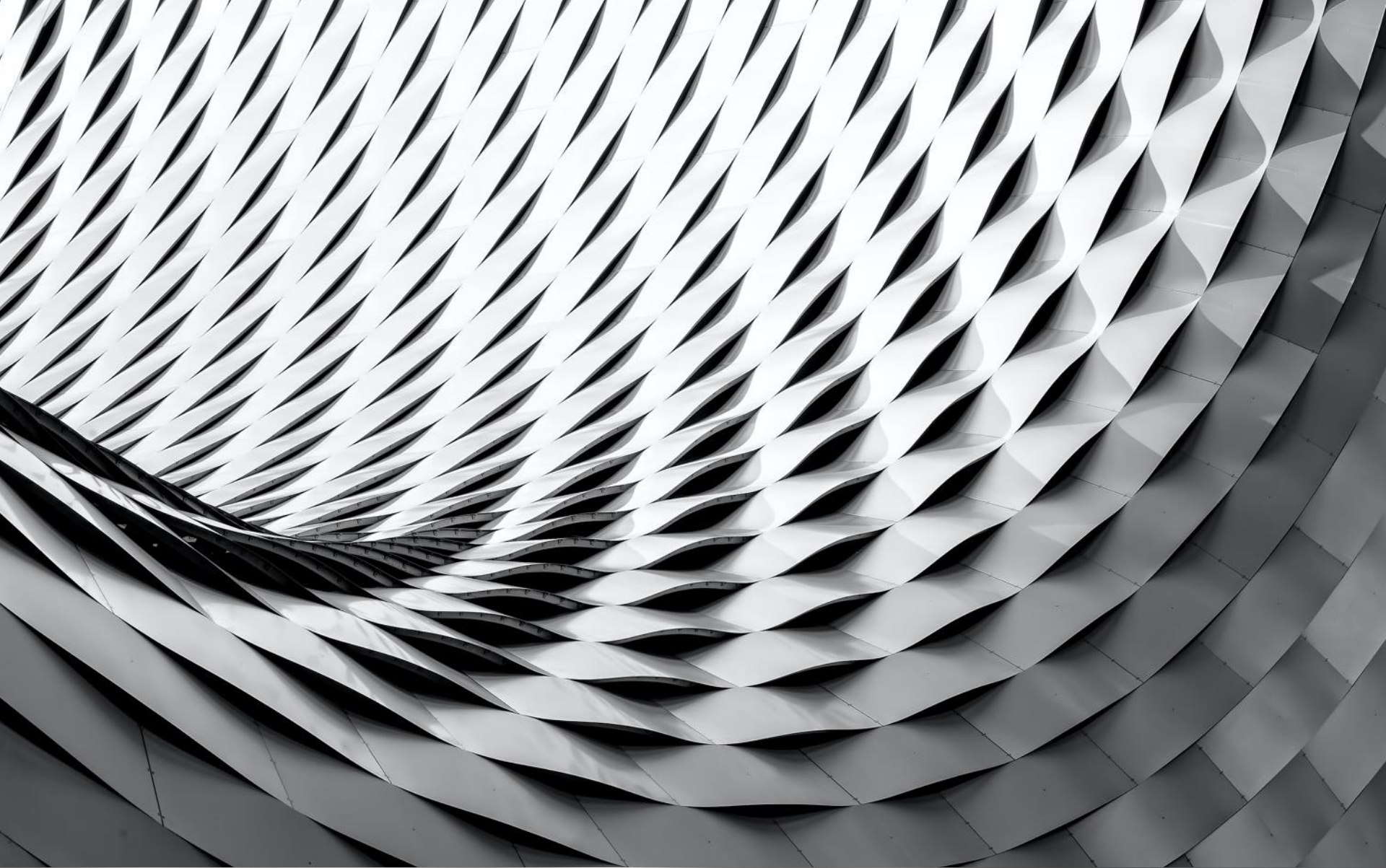

Riera Nadeu 

C. Cal Ros dels Ocells, 1-3. Pol Ind. Coll de la Manyà, 08403. Barcelona.
T_938 40 70 72 F_938 40 70 85 W_rieranadeu.com

